

FOUNDATION / MAST ELEVATION

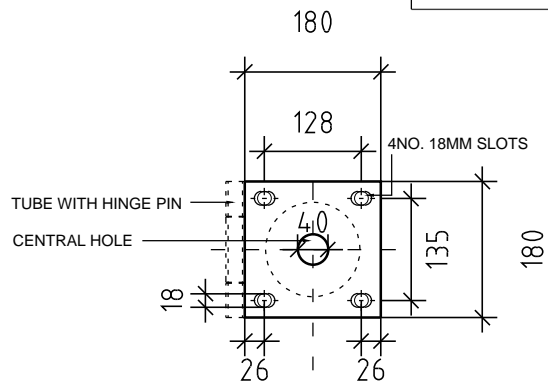

BASE PLATE PLAN

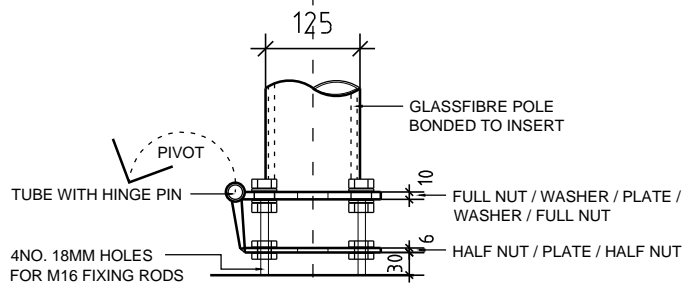

BASE PLATE / FOOT ELEVATION

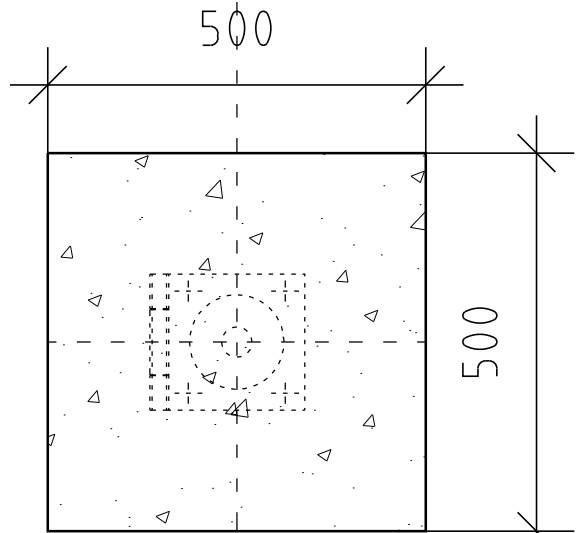

FOUNDATION PLAN

SINGLE LIGHT 125mm MAST - HEIGHT 1.8 - 4.9m

DETAILS OF STANDARD LIGHT HEIGHT ADJUSTER & DIFFERENT TOP CAP OPTIONS TO SUIT SFL UNITS ARE AVAILABLE SEPARATELY

NOTE: THE FOLLOWING PAD FOUNDATION DIMENSIONS ARE RECOMMENDATIONS ONLY. COMPETENT CIVIL ENGINEER TO DETERMINE ACTUAL FOUNDATION DIMENSIONS FOLLOWING SITE INVESTIGATION